

Module	MyALARM
Type of manual	Quick-start
Manual code	MI002433-E

THE FIRST CONFIGURATION

It is forbidden to insert or extract the SIM-CARD if the MyALARM is power on.

Before to insert the SIM-CARD into the MyALARM it is necessary, **using a mobile phone:**

- to active the SIM or ensure the SIM has already been activated
- to ensure no SMS are saved in the SIM
- to ensure the SIM has a sufficient value of credit
- to disable the PIN

At the first time, execute in the order the following operations:

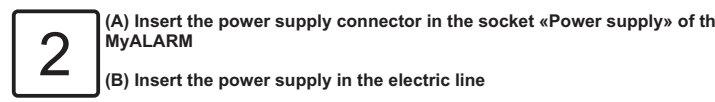
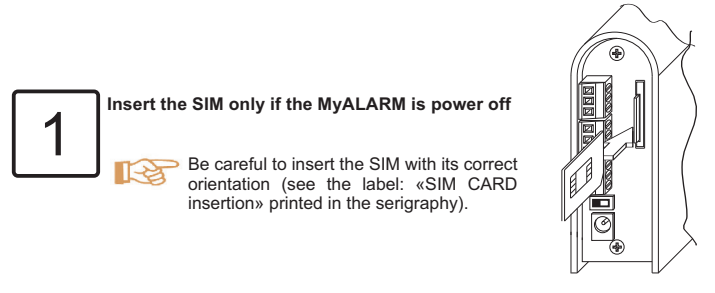

The connector is necessary to power the MyALARM. At this point, the green LED blinks slowly and the yellow LED blinks quickly.

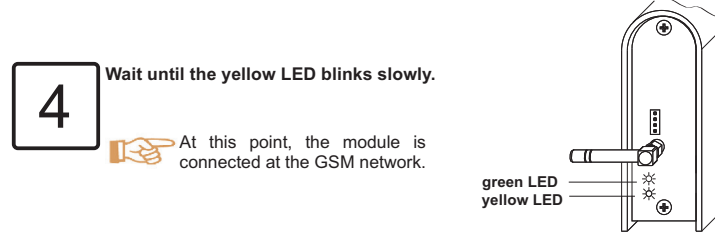
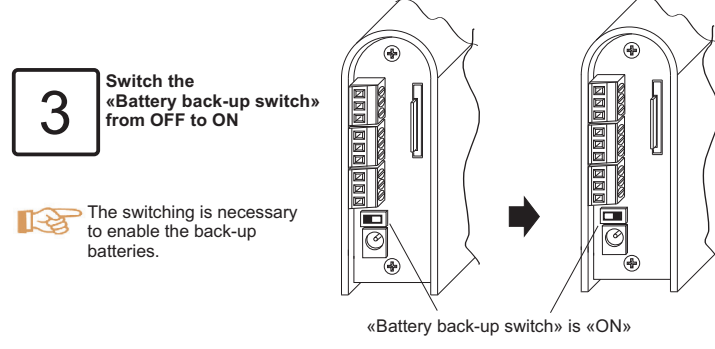
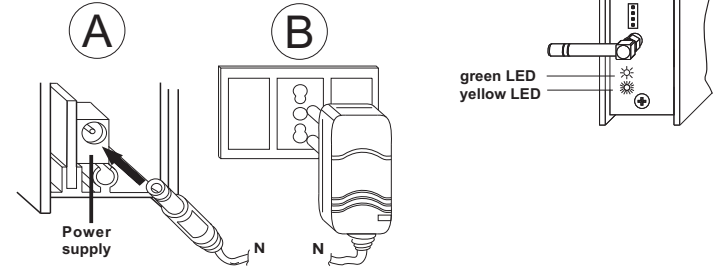

5 With the mobile phone you want to use to implement the telecontrol, call the MyALARM (with a calling duration: at least one ring). Anonymous phone numbers are not allowed.

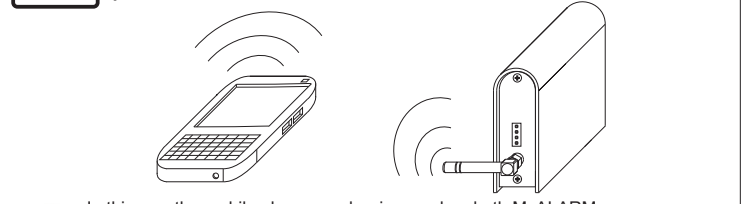

In this way the mobile phone number is saved on both MyALARM phonebooks (COMMANDS phonebook and ALARMS phonebook: this is valid only at the first ring and if the COMMANDS phonebook is empty).

At this point, the green LED is a constant light and the MyALARM can be used. **The MyALARM replies at the previous ring with a SMS** that displays:

- status of inputs, outputs
- hour of SMS sending (with reference to the GMT, Greenwich Mean Time: after the «+», are quarter of an hour GMT. Example: «+04» corresponds to four quarters of an hour, so 1 hour)
- temperature (in °C)
- amplitude of GSM signal (0/7 means no signal, 7/7 means max amplitude of signal)
- the progressive number referred to the notification SMS («0» at the first starting).

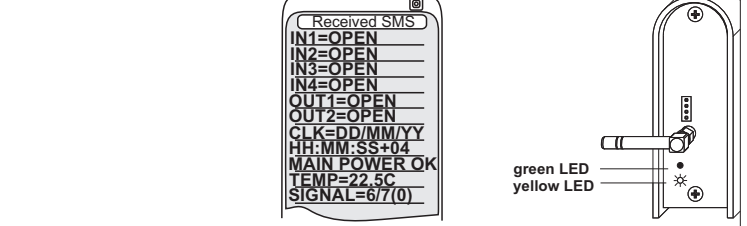

6 Depending on the SIM inserted into the MyALARM at the point 1, send one of the following commands to obtain the residue credit from mobile operator:

For SIM TIM: send to MyALARM the SMS with text «IDOPERATOR=1»
For SIM Wind: send to MyALARM the SMS with text «IDOPERATOR=2»
For SIM Vodafone: the first configuration was completed at the point 5.
For SIM of other operators: use the configuration software: Easy MyALARM or Easy Setup (this software is free-downloadable from www.seneca.it)

If the MyALARM receives this SMS correctly, the MyALARM performs a ring to the mobile phone to confirm that the operation has occurred.

REMINDER CARD

The MyALARM can be controlled from a mobile phone sending SMS commands: these ones are constituted by a number (SMS with text «0», «1»...up to «15»), each of them corresponds to a single operation. In particular, the following cards can be cut out and used as reminder about the data saved into the MyALARM:

- FAST commands
- password of the MyALARM (it's a four-digits number printed in the MyALARM case, necessary for example to reset the MyALARM). Two cards are shown: the first one is referred to the SMS default FAST commands, the other one can be compiled with custom commands (to modify the fast commands, use the software Easy MyALARM or Easy Setup).

SMS FAST COMMANDS - DEFAULT	
0_ Request of residue-credit	8_ Close the output 1
1_ Request of MyALARM-status	9_ Close the output 2
2_ Request of counter-values	10_ Close the timed output 1
3_ Request of totalizer-values	11_ Close the timed output 2
4_ Enable alarm if IN1 closed	12_ Open the output 1
5_ Disable alarm on IN1	13_ Open the output 2
6_ Enable alarm if IN2 closed	14_ Open the timed output 1
7_ Disable alarm on IN2	15_ Open the timed output 2

REMINDER CARD - MyALARM	PASSWORD
PASSWORD	
15	7
14	9
13	5
12	4
11	3
10	2
9	1
8	0
SMS FAST COMMANDS - CUSTOMIZED	

SOME APPLICATION EXAMPLES

The MyALARM allows to implement the following application examples, after that the first configuration is completed.

- Control of automatic gate
- Control of boiler
- Control of vending machine
- Anti-theft
- Control for solar panel
- Control of black-out
- Timed-automations
- Advanced automations

To implement these applications, use the software Easy MyALARM or Easy Setup.

MyALARM ACCESSORIES

BASE MODEL		
CODE	MY-0	DESCRIPTION
Unit to manage alarms and GSM-telecontrol, with power supply		
INPUT OPTIONS		
CODE	-FD01	DESCRIPTION
Photodiode / pulses-reader (10 Hz)		
CODE	-AA00	DESCRIPTION
No-flooding sensor/resistive sensor		
CODE	-RR00	DESCRIPTION
Relay reed - contact		
CODE	-AI00	DESCRIPTION
No-intrusion sensor with double technology		
OUTPUT OPTIONS		
CODE	-ER00	DESCRIPTION
Relay-outputs board (EASY-RELAY)		
INTERFACES		
CODE	-EU00	DESCRIPTION
EASY-USB (*)		
CODE	-AG00	DESCRIPTION
A-GSM (external antenna, cable lenght 3 m)		
ACCESSORIES FOR CONNECTION		
CODE	-FO00	DESCRIPTION
Plastic optical fiber for photovoltaic-plants alarm		
CODE	-MR00	DESCRIPTION
Remote screw terminal		
CODE	-GF00	DESCRIPTION
Mounting hooks		

(*) This interface is necessary to use the software Easy MyALARM or Easy Setup.

DIGITAL OUTPUT: CONNECTION WITH A RELAY

In order to help the user which needs to connect a relay to a MyALARM output, in the following figure is shown the connection between the two digital outputs with the EASY-RELAY device (accessory).

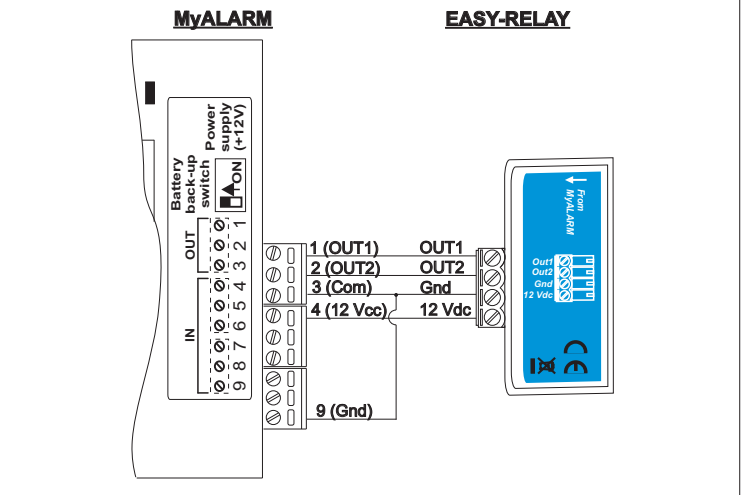

LIST OF EXECUTABLE COMMANDS BY A RING, EVENT, FAST COMMAND

The software Easy MyALARM or Easy Setup allows to program the MyALARM, so that

- with a ring to MyALARM, or
- in correspondence of an event, or
- sending a fast command to MyALARM

the MyALARM performs one of the following commands.

- NO OPERATION
- CLOSE OUT 1
- CLOSE OUT 2
- CLOSE TIMED OUT 1
- CLOSE TIMED OUT 2
- OPEN OUT 1
- OPEN OUT 2
- OPEN TIMED OUT 1
- OPEN TIMED OUT 2
- ENABLE ALARM IF IN 1 CLOSE
- ENABLE ALARM IF IN 1 OPEN

DIGITAL INPUTS

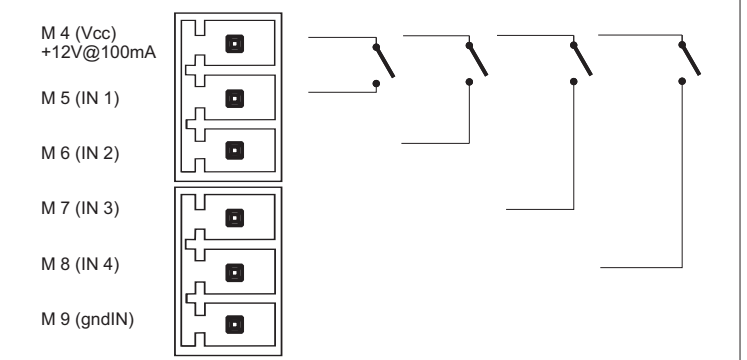

AN EXAMPLE OF CONNECTION ABOUT DIGITAL OUTPUTS: TWO OUTPUTS WITH EXTERNAL POWER SUPPLY

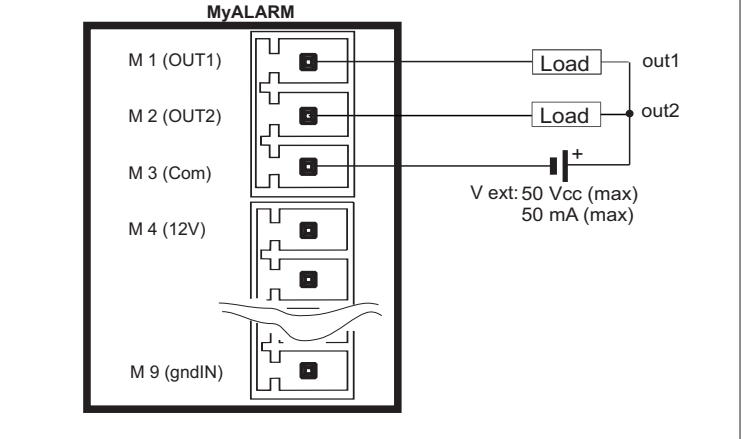

- ENABLE ALARM IF IN 2 CLOSE
- ENABLE ALARM IF IN 2 OPEN
- ENABLE ALARM IF IN 3 CLOSE
- ENABLE ALARM IF IN 3 OPEN
- ENABLE ALARM IF IN 4 CLOSE
- ENABLE ALARM IF IN 4 OPEN
- DISABLE ALARM FOR IN 1
- DISABLE ALARM FOR IN 2
- DISABLE ALARM FOR IN 3
- DISABLE ALARM FOR IN 4
- CHANGE STATUS FOR OUT 1
- CHANGE STATUS FOR OUT 2
- REQUEST OF RESIDUE CREDIT
- REQUEST OF ALARM-INPUT STATUS
- REQUEST OF COUNTER VALUES
- REQUEST OF TOTALIZER VALUES
- REQUEST OF INPUT 1 STATUS
- REQUEST OF INPUT 2 STATUS
- REQUEST OF INPUT 3 STATUS
- REQUEST OF INPUT 4 STATUS
- REQUEST OF MyALARM STATUS (default command)
- REQUEST OF COUNTER 1 AND RESET
- REQUEST OF COUNTER 2 AND RESET
- REQUEST OF COUNTER 3 AND RESET
- REQUEST OF COUNTER 4 AND RESET
- RESET COUNTER 1
- RESET COUNTER 2
- RESET COUNTER 3
- RESET COUNTER 4
- DISABLE RING COMMAND
- ENABLE RING COMMAND
- TOGGLE EN.IN.AL., TOGGLE OUT1, CLOSE OUT2 (*)
- ENABLE TIMER 1
- ENABLE TIMER 2
- ENABLE TIMER 3
- ENABLE TIMER 4
- DISABLE TIMER 1
- DISABLE TIMER 2
- DISABLE TIMER 3
- DISABLE TIMER 4
- DISABLE POSTPONED COMMAND (see pag.15/16 of this manual)
- ENABLE POSTPONED COMMAND (see pag.15/16 of this manual)
- ENABLE ALARM TMIN AND TMAX
- DISABLE ALARM TMIN AND TMAX
- TOGGLE ALARM TMIN TMAX AND OPEN OUT1 (*)

Using the software Easy, all previous commands can be combined with a fast command.
 (*) For more informations, see the help on line about software Easy MyALARM or Easy Setup.

SMS COMMANDS

COMAND	SINTAX	EXAMPLE
ADDCLK Adds or removes an offset (in seconds) at internal clock	ADDCLK = <offset_seconds>	ADDCLK = +3600 ADDCLK= - 1522
AL Returns the configuration of the input alarms	AL?	
ALCOUNT Returns the configuration of the counter alarms	ALCOUNT?	
ALCOUNTDIS Disable the counter alarms	ALCOUNTDIS = <chn>	ALCOUNTDIS = 1
ALCOUNTE Enable the counter alarms when the threshold is reached	ALCOUNTE = <chn>, <threshold>	ALCOUNTE = 1, 123456789
ALDIS Disable the alarm for inputs, blackout, temperature	ALDIS= <argument>	ALDIS = 1 (IN1) ALDIS = 2 (IN2) ALDIS = 3 (IN 3) ALDIS = 4 (IN4) ALDIS = POW (power supply) ALDIS = TMAX (temperature) ALDIS = TMIN (temperature)
ALEN Enable the alarms for input, blackout, temperature. It is possible to modify the thresholds for temperature	ALEN = <argument> [, <threshold>]	ALEN = 1,open (IN1) ALEN = 2,close (IN2) ALEN = 3 (IN 3) ALEN = 4 (IN4) ALEN = POW (power supply) ALEN = TMAX, -1.00 (temperature) ALEN = TMIN, 22.5 (temperature)

NOTE: in «example», in the rightmost column, the examples «ALEN=1,open» and «ALEN=2,close» are used to modify the status in correspondence of which the alarm is on (open for In1 and close for In2). Otherwise, the command «ALEN» refers to the last status saved in memory (ALEN=3, ALEN=4).

ALEN = TMIN, 16, 25 (enables the alarm on TMIN to 16°C, changes TMAX value to 25°C at the same time but this command does not enable the alarm on TMAX).
ALEN = TMAX, 22.5, 18.5 (enables the alarm on TMAX to 22.5°C, changes TMIN value to 18.5°C at the same time but this command does not enable the alarm on TMIN).

COMMAND	SINTAX	EXAMPLE
DELTA Sets the alarm on low-production or returns the configuration state	DELTA = <value>, <enable>, <mode>	DELTA? DELTA1? DELTA2? DELTA3? DELTA4? DELTA=D (to disable) For the other commands, see the examples in the note below

DELTA2=345,E,MONTH (enables alarm for low-production at the configured value: if the counter of input 2 - starting from 0 for example at the day 7/3 - does not exceed the value 345 within one month, automatically an alarm signalling occurs when the month is finished).
DELTA2=345,E,DAY (enables alarm for low-production at the configured value: if the counter of input 2 - starting from 0 for example at the day 7/3 - does not exceed the value 345 within the day after, automatically an alarm signalling occurs when the 24 hours are finished).
DELTA3=9,E,HOUR (enables alarm for low-production at the configured value: if the counter of input 3 - starting from 0 for example at 17:00 - does not exceed the value 9 within the hour after, automatically an alarm signalling occurs when 60 minutes are finished).

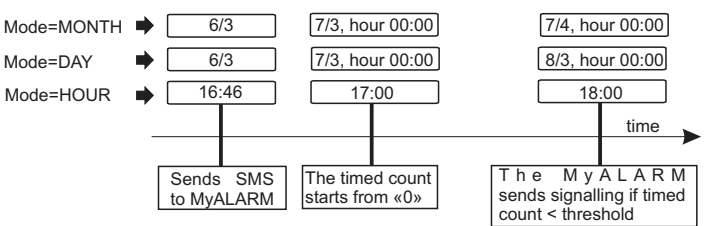

FACTORY Loads all default values, by deleting the actual configuration	FACTORY = <pass>	FACTORY = 3387
FWCODE Returns the firmware version	FWCODE?	
HYSTEMP Sets the hysteresis value for Tmin and Tmax alarm	HYSTEMP = <temperature>	HYSTEMP=+5 HYSTEMP=-1.1 HYSTEMP=1.1 HYSTEMP=0

COMMAND	SINTAX	EXAMPLE
NUMSIM Delete a phone number from the SIM extended phonebook about (to stop execution of the command on ring)	NUMSIM=<phone_number>	NUMSIM=+39 3331234567 NUMSIM=ALL
OPEN Open the digital output	OPEN=<chn>	OPEN = 1 OPEN = 2
PASS Returns the password	PASS?	
RINGCMD Returns or sets the command to perform on ring (see the page 7 and 8)	RINGCMD?	RINGCMD=NULL RINGCMD=STATUS? RINGCMD=COUNT? RINGCMD=CLOSE=1
SIMCONFIG Sets or returns the configuration about SIM card	SIMCONFIG? SIMCONFIG=DATA SIMCONFIG=VOICE SIMCONFIG=SMSCREDIT SIMCONFIG=RINGCREDIT SIMCONFIG=SWSMSDISABLE SIMCONFIG=SWSMSENABLE SIMCONFIG=PINENABLE,0000	
SMSCENTER Returns or configures the number of SMS service center	SMSCENTER? SMSCENTER=+00000000	
STATUS Returns the state of MyALARM	STATUS?	
TCLOSE Closes the digital output for a configurable duration	TCLOSE = <chn>, <seconds>	TCLOSE=1 TCLOSE=2 TCLOSE=1,20 TCLOSE=2,300

COMMANDS	SINTAX	EXAMPLE
TIMER Sets or returns a timer configuration	TIMER? TIMER=<enable>	TIMER? TIMER1? TIMER2? TIMER3? TIMER4? TIMER=ENABLE TIMER=DISABLE TIMER1=ENABLE TIMER1=DISABLE
TOGGLE Switches the status of a digital output	TOGGLE=<chn>	TOGGLE=1 TOGGLE=2
TOPEN Open an output for a desired time	TOPEN = <chn>, <seconds>	TOPEN= 1,20 TOPEN= 2,300
TOT Returns the value of totalizers	TOT?	
TOTE Returns and resets the value of a totalizer	TOTE#?	TOTE1? TOTE2? TOTE3? TOTE4?
TOTSET Sets the value of a totalizer	TOTSET=<chn>, <value>	TOTSET=1, 99999990 TOTSET=2, 99999990 TOTSET=3, 99999990 TOTSET=4, 99999990
POSTPONED COMMAND Execution of fast commands (at a given date/hour)	0-15, <+> <DD/MM/YYYY> <hh:mm:ss>	8 (the command combined with «8» is executed immediately) 8, 01/01/2012, 12:00 (the command combined with «8» will be executed at 01/01/2012, 12:00)

COMMAND	SINTAX	EXAMPLE
ALTOT Returns the configuration about the totalizer alarms	ALTOT?	
ALTOTDIS Disable the totalizer alarms	ALTOTDIS = <chn>	ALTOTDIS = 1 ALTOTDIS = 2 ALTOTDIS = 3 ALTOTDIS = 4
ALTOTEN Enable the totalizer alarms, sets a threshold value	ALTOTEN = <chn>, <threshold>	ALTOTEN = 1, 123456789 ALTOTEN = 2, 123456789 ALTOTEN = 3, 123456789 ALTOTEN = 4, 123456789
CAL Allows to set a temperature offset (in °C)	CAL = <offset_temp>	CAL=+10 CAL=-1.1 CAL=1.1 CAL=0
CFGOUT Sets N.C. or N.O. on the digital outputs (or returns the configuration)	CFGOUT? CFGOUT = <chn>, <state>	CFGOUT? CFGOUT = 1, NC CFGOUT = 1, NO CFGOUT = 2, NC CFGOUT = 2, NO
CLK Sets or returns the clock value (after +, are quarters of an hour)	CLK? CLK = dd/mm/yyyy hh:mm:ss +GMT	CLK? CLK = 1/2/12 8:40:53 +4 CLK = 1/2/2012 8:40:53 +4
CLOSE Closes a digital output	CLOSE = <chn>	CLOSE=1 CLOSE=2
COUNT Returns counter values	COUNT?	
COUNTE Returns counter values and, then, resets these values (to «0»)	COUNTE= <chn>	COUNTE = 1 COUNTE = 2 COUNTE = 3 COUNTE = 4 COUNTE = ALL
COUNTSET Writes a desired value to a counter	COUNTSET= <chn>, <value>	COUNTSET = 1, 999999990 COUNTSET = 2, 999999990 COUNTSET = 3, 999999990 COUNTSET = 4, 999999990
CREDIT Returns the residue credit	CREDIT?	
CREDITPARAM Sets the SMS for the residue credit request or returns the actual message	CREDITPARAM? CREDITPARAM = <message>	CREDITPARAM=PRE CRE SIN CREDITPARAM = Saldo

COMMAND	SINTAX	EXAMPLE
HYSTIME Sets the inhibition time about input alarms before generate the next one	HYSTIME = <argument>, <minutes>	HYSTIME=1, 5 HYSTIME=2, 300 HYSTIME=3, 26 HYSTIME=4, 5 HYSTIME=POW, 3
IDOPERATOR Sets or returns the configuration about mobile-phone operator	IDOPERATOR? IDOPERATOR=<id>	IDOPERATOR=0 IDOPERATOR=1 IDOPERATOR=2
IN Returns the value of digital inputs	IN#?	IN1? IN2? IN3? IN4?
NUMCREDIT Returns or sets the number used to request the residue credit	NUMCREDIT? NUMCREDIT=+404 NUMCREDIT=+40916 NUMCREDIT=+4155	
NUMIN Returns or adds a phone number into command phonebook	NUMIN? NUMIN=<phone_number>	NUMIN? NUMIN=+39 3331234567
NUMINE Erase a phone number from the command phonebook	NUMINE=<phone_number>	NUMINE=+39 3331234567
NUMOUT Returns or adds a phone number into alarm phonebook	NUMOUT? NUMOUT=<phone_number>	NUMOUT=+39 3331234567
NUMOUTE Erase a phone number from the alarm phonebook	NUMOUTE= <phone_number>	NUMOUTE=+39 3331234567
NUMSIM Adds a phone number at extended phonebook of SIM (to perform a command corresponding to a ring)	NUMSIM=<phone_number>	NUMSIM=+39 3331234567

COMMAND	SINTAX	EXAMPLE
NUMSIM Delete a phone number from the SIM extended phonebook about (to stop execution of the command on ring)	NUMSIM=<phone_number>	NUMSIM=+39 3331234567 NUMSIM=ALL
OPEN Open the digital output	OPEN=<chn>	OPEN = 1 OPEN = 2
PASS Returns the password	PASS?	
RINGCMD Returns or sets the command to perform on ring (see the page 7 and 8)	RINGCMD?	RINGCMD=NULL RINGCMD=STATUS? RINGCMD=COUNT? RINGCMD=CLOSE=1
SIMCONFIG Sets or returns the configuration about SIM card	SIMCONFIG? SIMCONFIG=DATA SIMCONFIG=VOICE SIMCONFIG=SMSCREDIT SIMCONFIG=RINGCREDIT SIMCONFIG=SWSMSDISABLE SIMCONFIG=SWSMSENABLE SIMCONFIG=PINENABLE,0000	
SMSCENTER Returns or configures the number of SMS service center	SMSCENTER? SMSCENTER=+00000000	
STATUS Returns the state of MyALARM	STATUS?	
TCLOSE Closes the digital output for a configurable duration	TCLOSE = <chn>, <seconds>	TCLOSE=1 TCLOSE=2 TCLOSE=1,20 TCLOSE=2,300

COMMANDS	SINTAX	EXAMPLE
TIMER Sets or returns a timer configuration	TIMER? TIMER=<enable>	TIMER? TIMER1? TIMER2? TIMER3? TIMER4? TIMER=ENABLE TIMER=DISABLE TIMER1=ENABLE TIMER1=DISABLE
TOGGLE Switches the status of a digital output	TOGGLE=<chn>	TOGGLE=1 TOGGLE=2
TOPEN Open an output for a desired time	TOPEN = <chn>, <seconds>	TOPEN= 1,20 TOPEN= 2,300
TOT Returns the value of totalizers	TOT?	
TOTE Returns and resets the value of a totalizer	TOTE#?	TOTE1? TOTE2? TOTE3? TOTE4?
TOTSET Sets the value of a totalizer	TOTSET=<chn>, <value>	TOTSET=1, 99999990 TOTSET=2, 99999990 TOTSET=3, 99999990 TOTSET=4, 99999990
POSTPONED COMMAND Execution of fast commands (at a given date/hour)	0-15, <+> <DD/MM/YYYY> <hh:mm:ss>	8 (the command combined with «8» is executed immediately) 8, 01/01/2012, 12:00 (the command combined with «8» will be executed at 01/01/2012, 12:00)